

# Operating Principles

## OP08 - Electrochemical 3-Electrode Un-biased Toxic Sensors

### CONTENTS

Introduction	2
Operating Principles	2
Recommended Circuitry	4
Start-up Time	5
Calibration Guidelines	5
Selectivity and Filters	7
Safety Monitoring	7
Continuous Exposure to Target Gas	8
Effects of Temperature, Pressure and Humidity	8
Sensor Mounting	10
Handling and Storage	10

### Document Purpose

The purpose of this document is to describe the functionality of the product, and to provide information and advice regarding the appropriate use of the sensors.

This document and the information contained within does not constitute a specification. This document should be used in conjunction with the Product Datasheet, the Product Characterisation Note (where available) and the Product Safety Datasheet.

## Operating Principles

### Introduction

The toxic Gas CiTiceL development programme began in 1981 with the introduction of the Carbon Monoxide CiTiceL. Since then new CiTiceLs have been developed for various toxic gases, resulting in a range of sensors with an enviable reputation for reliability, stability and robust design.

These sensors are micro fuel cells, designed to be maintenance-free and stable for long periods. They use the technology that was pioneered with the original Oxygen CiTiceL, which results in a direct response to volume concentration rather than partial pressure. The central feature of the design is the gaseous diffusion barrier, which limits the access of gas to the Sensing electrode. The electrode is therefore able to react all target gas as it reaches its surface and still has electrochemical activity in reserve. This high activity reserve ensures each CiTiceL has a long life and excellent temperature stability.

### Operating Principles

#### **The Two Electrode CiTiceL®**

The simplest form of sensor operating on electrochemical principles has two electrodes (Sensing and Counter) separated by a thin layer of electrolyte and connected by a low resistance external circuit. Gas diffusing into the sensor is reacted at the surface of the Sensing electrode by oxidation or reduction, causing a current to flow between the electrodes through the external circuit. The current is proportional to the concentration of gas and can be measured across a load resistor in the external circuit.

For reaction to take place, the Sensing electrode potential must be within a specific range. As the gas concentration increases so does the current flow, causing a change in the potential of the Counter electrode (polarisation). With the electrodes connected together by a simple load resistor, the Sensing electrode potential follows that of the Counter. If the gas concentration continues to rise, the Sensing electrode potential will eventually move outside its permitted range. At this point the sensor will become non-linear, effectively limiting the upper concentration of gas a two electrode sensor can be used to measure.

#### **The Three Electrode CiTiceL®**

The limitation imposed by Counter electrode polarisation can be avoided by introducing a third, Reference electrode, and by using an external potentiostatic operating circuit. With this arrangement, the Sensing electrode is held at a fixed potential relative to the Reference electrode. No current is drawn from the Reference electrode, so both maintain a constant potential. The Counter electrode is still free to polarise, but this has no effect on the Sensing electrode and so does not limit the sensor in any way. Consequently the range of concentrations a three electrode sensor can be used to measure is much greater.

Many of City Technology's electrochemical sensors incorporate a three electrode design and are generally used with a potentiostatic circuit. By controlling the potential of the Sensing electrode, the potentiostatic circuit allows greater selectivity and improved response to the target gas. The same circuit is used to measure the current flow between the Sensing and Counter electrodes.

# Operating Principles

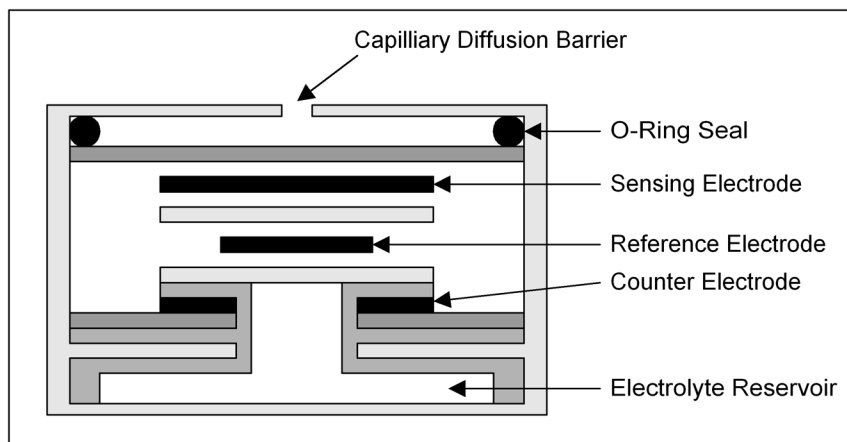

Toxic Gas CiTiceL<sup>®</sup> Schematic Drawing

## The Four Electrode CiTiceL<sup>®</sup>

Further development of the three electrode design has led to development of a number of four electrode sensors, one of which is the 4COSH CiTiceL<sup>®</sup>.

The 4COSH has an additional sensing electrode known as the Auxilliary electrode, which allows it to detect two gases simultaneously (CO and H<sub>2</sub>S). The two sensing electrodes provide distinct output signals for the two different gases.

Other 4-electrode sensor designs utilise an Auxiliary electrode which can be utilised to provide hydrogen compensation, baseline compensation or scavenging of oxidation by-products.

## Reaction Mechanisms

Gas diffusing into a CiTiceL<sup>®</sup> is reacted at the Sensing electrode by oxidation (most gases) or reduction (e.g. nitrogen dioxide and chlorine). Each reaction can be represented in standard chemical equation form. The oxidation of carbon monoxide, for example, at the Sensing electrode can be represented by the equation:-

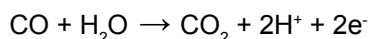

A similar equation can be derived for other CiTiceLs<sup>®</sup>, depending on the reaction of the target gas on the Sensing electrodes. Some examples are below.

Chlorine (Cl <sub>2</sub> ) :	$\text{Cl}_2 + 2\text{H}^+ + 2\text{e}^- \rightarrow 2\text{HCl}$
Hydrogen (H <sub>2</sub> ) :	$\text{H}_2 \rightarrow 2\text{H}^+ + 2\text{e}^-$
Hydrogen Cyanide (HCN) :	$2\text{HCN} + \text{Au} \rightarrow \text{HAu}(\text{CN})_2 + \text{H}^+ + \text{e}^-$
Hydrogen Sulphide (H <sub>2</sub> S) :	$\text{H}_2\text{S} + 4\text{H}_2\text{O} \rightarrow \text{H}_2\text{SO}_4 + 8\text{H}^+ + 8\text{e}^-$
Nitrogen Dioxide (NO <sub>2</sub> ) :	$\text{NO}_2 + 2\text{H}^+ + 2\text{e}^- \rightarrow \text{NO} + \text{H}_2\text{O}$
Phosphine (PH <sub>3</sub> ) :	$\text{PH}_3 + 4\text{H}_2\text{O} \rightarrow \text{H}_3\text{PO}_4 + 8\text{H}^+ + 4\text{e}^-$
Silane (SiH <sub>4</sub> ) :	$\text{SiH}_4 + 2\text{H}_2\text{O} \rightarrow \text{SiO}_2 + 8\text{H}^+ + 8\text{e}^-$
Sulphur Dioxide (SO <sub>2</sub> ) :	$\text{SO}_2 + 2\text{H}_2\text{O} \rightarrow \text{H}_2\text{SO}_4 + 2\text{H}^+ + 2\text{e}^-$

## Operating Principles

The Counter electrode acts to balance out the reaction at the Sensing electrode. If oxidation occurs at the Sensing electrode, oxygen will be reduced to form water at the Counter. If, however, the Sensing electrode reaction is a reduction, the Counter electrode reaction will be reversed (i.e. water will be oxidised). The standard equation for this electrode can be written as:-

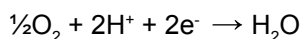

The equations for the two electrodes can be combined and simplified to give an overall cell reaction. In the case of carbon monoxide, for example, this can be written as:-

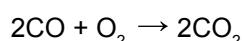

This overall equation demonstrates that the fuel for the reactions are gases supplied to the sensor, and the product is a gas emitted. In other words the sensor is merely a catalyst for the reaction, and no part of it is directly consumed (Note: except in the case of the Ammonia and Hydrogen Cyanide CiTiceLs - see below).

Note: Hydrogen Cyanide CiTiceLs employ a novel electrolyte, in which the reaction mechanism is not straightforward oxidation or reduction as used in other sensors. This has important consequences on their performance, especially on output drift and operating life. The sensors are therefore suitable for leak detection, but not applications where high concentrations or continuous exposures are likely. The specifications quoted in the data sheets assume the total monthly exposure does not exceed a specified level.

### Recommended Circuitry

The recommended circuit for use with un-biased 3-electrode Toxic CiTiceLs<sup>®</sup> is shown below. The output from the circuit will be positive with respect to common for sensors measuring oxidising gases, and negative with respect to common for sensors measuring reducing gases.

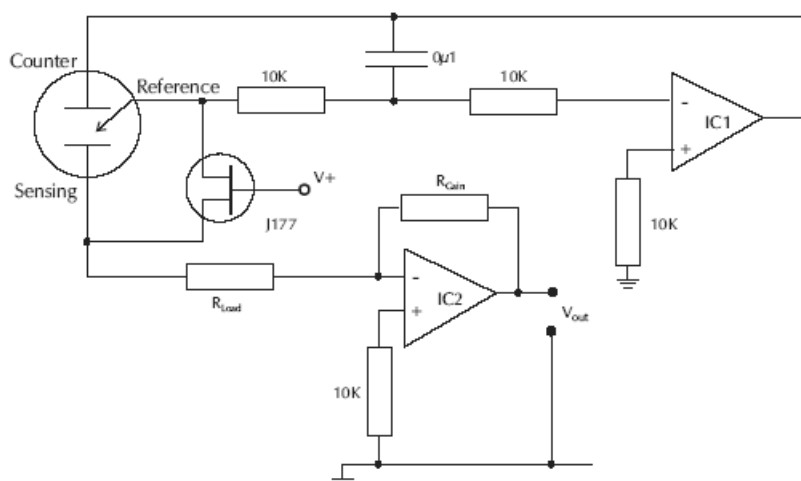

IC1 - This amplifier should have either a low offset or have its offset nulled out. The PMI OP-77 and OP-90 and Linear Technology LT1078 are all suitable.

IC2 - This amplifier acts as a current to voltage converter and its offset performance is less critical. The OP-77 or similar is a suitable choice

Recommended value of  $R_{load}$  is given in the datasheet.

Recommended Circuitry for 3-electrode un-biased toxic CiTiceLs<sup>®</sup>

## Operating Principles

The function of the Counter electrode is to complete the electrochemical circuit and its potential relative to the Sensing and Reference electrodes is not fixed by the circuit. Under quiescent conditions, the cell is drawing a very small current and the Counter electrode will be near its rest potential. When gas is detected, the cell current rises and the Counter electrode polarises (negatively) with respect to the Reference electrode.

While the cell current stabilises very quickly, the Counter electrode polarises slowly and may continue to drift even though the sensor signal is stable. This is normal, and in practice the maximum Counter electrode polarisation likely is 300-400 mV with respect to the Reference electrode. In practical terms this means the circuit ground should be derived at a higher value than the negative supply rail (e.g. 1 V), so that IC1 can give a negative output.

It is important, on switch on, that IC1 has a low offset (e.g. <math><100 \mu\text{V}</math>), or the op amp will effectively bias the sensor. The sensor will then take a correspondingly long time to settle down from the shorted condition.

The voltage developed across  $R_{\text{Load}}$  should be restricted to less than 10 mV under all conditions otherwise sensor performance will suffer. Keeping  $R_{\text{Load}}$  low also ensures a faster response time, and although in this circuit it can be reduced to zero, a small finite value is recommended. This ensures a better balance between circuit noise and response time, and in some cases reduces the humidity transient.

### Start-up Time

To maintain a sensor in a 'ready to work' condition, the sensor is supplied with a shorting link across the Sensing and Reference terminals. This must remain in place during storage, and should only be removed when the sensor is ready to be used. Once in use, a sensor will require a long start up time if the electrodes are not reshorted when the instrument is switched off (typically up to 12 hours). In the recommended circuit, this is achieved by a shorting J-FET which keeps the electrodes shorted when the circuit is unpowered. While shorted it is important to avoid exposure to active gases or solvent vapours.

### Calibration Guidelines

CiTiceLs® provide very stable signals over time and for many applications, instruments containing CiTiceLs® only require periodic recalibration. The time interval required between initial calibration and subsequent recalibrations is dependant on various factors. In strenuous applications involving extremes of operation, or for sensors used in safety applications, frequent instrument calibration may be required.

Electrochemical gas sensors need a certain amount of oxygen to function. Generally, a few thousand ppm oxygen is sufficient. However, as calibration normally involves exposing the sensing face of the CiTiceL to gas for a relative short period of time, a calibration gas need not contain oxygen - sufficient is supplied from the ambient air, for a limited time. In most cases, a five minute exposure time is sufficient to achieve a stable calibration signal.

**Safety Note :** Many CiTiceLs are designed to be used in safety critical applications. To ensure that the sensor and/or instrument in which it is used, is operating properly, it is a requirement that the function of the device is confirmed by exposure to target gas (bump check) before each use of the sensor and/or instrument. Failure to carry out such tests may jeopardize the safety of people and property.

## Operating Principles

### Calibration Period

The calibration and, if necessary, adjustment procedures demonstrate that the gas detection apparatus is able to measure the target gas with sufficient accuracy. However, between calibrations, the performance of the apparatus is unknown and the deviations are likely to increase with time.

When choosing a suitable calibration period, factors such as sensor characteristics, type of apparatus, static and dynamic conditions of temperature and humidity, dust, poisoning, corrosive atmospheres and experience of the user in similar situations should be considered.

Appropriate calibration periods can range from days to months. It is good practice to determine the calibration period as follows:

- a) if there is sufficient reliability and stability data available for the apparatus and sensors used in a specific application, the calibration period can be derived from this data for applications with similar operating conditions.
- b) if sufficient data is not available, two calibrations should be conducted at short intervals following commissioning. If it is not necessary to adjust the apparatus at these calibrations, the interval can be increased. This procedure should be repeated until the calibration period specified in the instruction manual is reached. An appropriate short interval could be four weeks, as an example.
- c) if adjustment is necessary at two successive calibrations, the calibration period should be shortened until no such adjustment is necessary. If the final calibration period is unreasonably short, a more suitable measuring principle should be considered.

An adjustment is necessary if the deviation of the measured value is outside the limits required by the application or if the minimum requirements for stability of the apparatus as defined in EN 45544-2 and EN 45544-3 are not met. EN 45544-2 states that the deviation within one calibration period should not exceed the lower limit of measurement in clean air and 20 % of the measured value in test gas. EN 45544-3 states that the deviation within one calibration period should not exceed 10 % of the measuring range in clean air and 20% of the measured value in test gas.

### Calibration Gas Concentration

For maximum accuracy, the sensor should be calibrated using a gas mixture in the range where most measurements are to be made. Where this is not possible, a mixture towards the top of the CiTiceL range should be chosen. Calibration gases exceeding the range of the CiTiceL must not be used as this may not provide an accurate calibration.

Electrochemical gas sensors need a certain amount of oxygen to function. Generally, a few thousand ppm oxygen is sufficient. However, as calibration normally involves exposing the sensing face of the CiTiceL to gas for a relative short period of time, a calibration gas need not contain oxygen - sufficient is supplied from the ambient air, for a limited time. In most cases, a five minute exposure time is sufficient to achieve a stable calibration signal.

### Calibrating to Cross Sensitive Gases

Electrochemical CiTiceLs are cross sensitive to certain non-target gases. Information regarding cross sensitivities for particular sensors can be found on the product datasheets. It is important to remember however, that cross sensitivity data is only very approximate and cross sensitivities will vary between sensors and sensor batches. Therefore, it is not advisable to calibrate sensors or transmitters to non-target gas as this will result in a degree of measurement error.

# Operating Principles

## Recommended Gas Flow Rates

A minimum flow rate is required to ensure accurate calibration - it also means that the response from a CiTiceL is equivalent in configurations where gas is flowing over the sensor and those where the sample is allowed to diffuse into the sensor. The minimum flow rate which is required will be different depending on the CiTiceL type - these are shown in the table below.

Gas	Sensor Type	Minimum Flow Rate (ml/min)
Ammonia, NH <sub>3</sub>	All types	250
Arsine, AsH <sub>3</sub>	All types	250
Carbon Monoxide, CO	Surecell CO	400
	All other types	150
Chlorine, Cl <sub>2</sub>	Sensoric types	500
	All other types	1000
Chlorine Dioxide, ClO <sub>2</sub>	All types	250
Fluorine, Fl <sub>2</sub>	All types	500
Hydrazine, N <sub>2</sub> H <sub>4</sub>	All types	500
Hydrogen, H <sub>2</sub>	All types	150
Hydrogen Cyanide, HCN	3HCN, 7HCN	400
	4HN	100
	Sensoric types	250
Hydrogen Fluoride, HF	All types	500
Hydrogen Sulfide, H <sub>2</sub> S	3HH(-LM) 7HH(-LM)	400
	All other types	250
Mercaptan, TBM	All types	250
Nitrogen Dioxide, NO <sub>2</sub>	3NDH, 7NDH	1000
	3ND, 4ND, 5ND	400
	Sensoric types	250
Phosgene, COCl <sub>2</sub>	All types	500
Phosphine, PH <sub>3</sub>	All types	600
Ozone, O <sub>3</sub>	All CiTiceL types	1000
	All Sensoric types	250
Silane, SiH <sub>4</sub>	All types	250
Sulfur Dioxide, SO <sub>2</sub>	3SH, 7SH	1000
	4S, 3ST/F, 7ST/F, 3SF(/F), 5SF(/F)	400

These flow rates are based on gas delivery apparatus used at City Technology Ltd. Other designs of gas delivery may have an influence on the flow rates required.

The reaction mechanism consumes target gas - this means that the concentration of target gas will be depleted immediately in front of the CiTiceL<sup>®</sup>. The minimum flow rates are set such that the CiTiceL<sup>®</sup> is exposed to a constant concentration of target gas - the flow rate is great enough to ensure that any depleted concentration is immediately replaced. This mimics the situation where the sample diffuses to the CiTiceL<sup>®</sup> - there will be a large volume of target gas so that the depletion is immediately replaced - via diffusion.

# Operating Principles

## **Selectivity and Filters**

The choice of electrode material has a strong influence on the gas a sensor will respond to. The CiTiceLs® are designed to be highly specific to the target gas, and cross sensitivities to other gases have been minimized by careful design of the electrode catalyst.

Some sensors have inboard filters to remove gases that would otherwise react on the Sensing electrode. Each filter is designed to remove certain gases from a sample before it reaches the Sensing electrode, so eliminating certain cross sensitivities. All filters have a lifetime (generally expressed in ppm hours), after which the filter will no longer remove the interfering gases from the gas stream.

As these inboard filters are built into the sensor during manufacture, they do not alter the external dimensions of the CiTiceL®. Note that not all sensors have inboard filters. Details can be found on the Product Datasheet.

## **Safety Monitoring**

For applications concerned with personnel safety, an instrument is required to signal when the Short-Term Exposure (STEL) and the Long-Term Exposure (TWA) limits are reached.

Sensors used in safety applications should be fully calibrated at least every six months. However as safety is of paramount importance, it is recommended that users of gas detectors containing electrochemical sensors conduct a regular 'bump' check before relying on the unit to verify an atmosphere is free from hazard.

A 'bump' check is a means of verifying that an instrument is working within acceptable limits by briefly exposing it to a known gas mixture formulated to change the output of all the sensors present. This is different from a calibration where the instrument is also exposed to a known gas mixture but is allowed to settle to a steady figure and the reading adjusted to the stated gas concentration of the test mixture.

## **Continuous Exposure to Target Gas**

Our Toxic Gas CiTiceLs® have been designed for intermittent monitoring of target gases and are generally unsuitable for continuous monitoring applications, particularly those involving high concentrations of gases or extremes of humidity and temperature. Continuous monitoring may sometimes be achieved by cycling two (or even three) sensors in and out of the gas stream, such that each sensor is only exposed to gas for up to one half the time, being allowed to recover in fresh air for the other half.

## Operating Principles

### Effects of Temperature, Pressure and Humidity

#### Temperature Dependence

Both the span signal and the baseline (zero gas current) are affected by temperature.

The output from a CiTiceL<sup>®</sup> will only vary slightly with gradual changes in temperature. However, a rapid change in temperature may result in a transient response from the sensor. This transient will typically die away after about 20-30 seconds and the output will settle at a new level dependant upon the temperature.

#### Pressure Effects

CiTiceLs<sup>®</sup> give a transient response when exposed to sudden changes in pressure in the presence of a measured gas. The peak signal decays in only a few seconds. This can be a particular problem when using sampling pumps, as they may introduce pressure fluctuations into the gas stream.

Pressure pulsations can be avoided by ensuring the sensor is positioned at the atmospheric end of the sample train. Alternatively a flow restriction placed upstream from the CiTiceL<sup>®</sup> will also help to damp out pressure scillations.

Another effective measure is to ensure that the back pressure downstream from the CiTiceL<sup>®</sup> is effectively zero, so allowing an unrestricted flow of gas to ambient air. However, it is important to prevent back diffusion from the ambient air diluting the gas stream and lowering the gas concentration being measured. Back diffusion can be reduced, for example, by the provision of an exhaust gas tube of 4mm internal diameter and 8mm length.

#### Humidity Effects

Most toxic gas CiTiceLs<sup>®</sup> are based on the use of aqueous electrolytes which, in conjunction with the porous diffusion barrier, permit water vapour to be absorbed into the electrolyte under conditions of high water vapour pressure and allow the electrolyte to dry out at very low ambient water vapour pressure. Provided conditions are non-condensing, the performance is relatively unaffected by humidity and will simply follow the change in concentration of the measured gas which results from changes in humidity. However when rapid changes in humidity occur, the sensor may show a transient response which should die away after about 20-30 seconds.

In many cases, continuous operation is possible between 15% and 90% RH over the full operating temperature range. Under these conditions, the electrolyte will reach an equilibrium with the external water vapour pressure at a volume and concentration which does not affect the sensor's life or performance. Operation is also possible outside these conditions, but water transfer may occur and must be considered.

Datasheets for certain sensors quote conditions for both continuous and intermittent operation – please refer to Product Datasheet.

#### High Humidity, High Temperature

Under continuous operation at high temperatures and 90-100% RH, water will slowly diffuse in. However water uptake is only harmful when the liquid volume increase exceeds the free space available. When this happens the sensor becomes prone to leakage - increasingly so as more and more water is taken up by the sensor. Removal from this humidity to a lower RH before leakage occurs will gradually restore the sensor to its original condition and no permanent harm will result from the exposure.

If a sensor shows signs of being affected by condensation, drying it with a soft tissue will restore normal operation. Under no circumstances should sensors be heated above 40°C to dry them out.

# Operating Principles

## Low Humidity, High Temperature

Similarly in continuous operation at 0-15% RH water will diffuse out. This will only be a problem when the volume of electrolyte has decreased by more than 40%, at which point the sensor gas sensitivity will be affected and the housing and seals may be attacked by the very concentrated electrolyte. Provided a sensor is not left in this condition long enough for such a reduction in the electrolyte to take place, it can be restored by exposure to a RH above 15%. At this level, water ingress will begin to restore the water balance.

The rate at which water transfer occurs depends on the ambient temperature and relative humidity at the sensor. It also depends on the electrolyte and capillary hole size, both of which vary from one type of CiTiceL<sup>®</sup> to another. In general, low sensitivity CiTiceLs<sup>®</sup> will have slower water transfer rates and can be used for longer periods of time, whereas high sensitivity CiTiceLs<sup>®</sup> (e.g. 4ND) will have higher water transfer rates, and should be operated for shorter periods of time in these conditions.

## Sensor Mounting

CiTiceLs<sup>®</sup> are not sensitive to orientation and can be mounted in any orientation with no effect on performance. IMPORTANT NOTE: Sensor pins must not be soldered to, as excessive heat will damage the sensor.

## Handling and Storage

CiTiceLs are relatively insensitive to mishandling and following the simple guidelines given below should ensure correct operation.

- CiTiceLs may be stored for up to six months, during which time they should be kept sealed in the container in which they were supplied or in clean air and within the temperature range given on the product data sheet.
- CiTiceLs should not be stored in areas containing solvent vapours.
- It is important to be aware that reactive species can diffuse into and reside un-reacted on a CiTiceL until the instrument they are in is switched on and the sensor is operational. Once powered, the resulting reaction can cause a temporary high baseline.
- It is important to avoid using CiTiceLs in close proximity to alcohol containing antiseptic products, such as wipes and sanitizing gels, or handling CiTiceLs if these products have recently been used. CiTiceLs can respond to the alcohol based solvents contained within these and generate an output, which could manifest itself as an exaggerated baseline signal or prolonged recovery time.
- CiTiceLs must not be subjected to any pressure when handling or clamping.
- At the end of its life, please dispose of CiTiceLs in accordance with local regulations. The hazardous waste disposal regulations depend on geographic location, and local regulations should be checked before discarding sensors. Product Safety Datasheets (PSDS's) are available for all City Technology products, detailing their hazardous content.

Every effort has been made to ensure the accuracy of this document at the time of printing. In accordance with the company's policy of continued product improvement City Technology Limited reserves the right to make product changes without notice. No liability is accepted for any consequential losses, injury or damage resulting from the use of this document or from any omissions or errors herein. The data is given for guidance only. It does not constitute a specification or an offer for sale. The products are always subject to a programme of improvement and testing which may result in some changes in the characteristics quoted. As the products may be used by the client in circumstances beyond the knowledge and control of City Technology Limited, we cannot give any warranty as to the relevance of these particulars to an application. It is the clients' responsibility to carry out the necessary tests to determine the usefulness of the products and to ensure their safety of operation in a particular application.