

Specification Datasheet - 8010034

Fathom Dive Systems LLC.
FDS100 Oxygen Sensor



© Vandagraph Sensor Technologies Ltd.

v1.0
17th March 2026

Specifications

VST part number	8010034
OEM model number	FDS100 Oxygen Cell
Initial output signal in ambient air	9 – 13 mV
Output connector	Radiall SMB Series R114.426.000 straight male receptacle for PCB, solder legs
Input	Threaded M16 x 1mm
Input O ring	No
Range	0 – 100% oxygen
Pressure range	600 to 2500 mbar
Repeatability	<1% volume oxygen at constant temperature and pressure
Linearity error	0.1 to 1.0 bar < 3% relative 0.1 to 2.5 bar < 5% relative (at ppO ₂ > 1.0 bar after 1 hour equilibration time)
Warm up time	< 30 minutes after sensor installed
Zero offset voltage	< 0.5% oxygen reading in 100% nitrogen @ 25 °C after 36 seconds
Cross interference	< 0.5% volume oxygen response to 5% CO ₂ balance N ₂
Response time	< 5 s for 90% of final value.
Operating humidity	0 – 99% R.H. (non-condensing).
Influence of humidity	- 0.03% relative per % R.H. at 25 °C.
Influence of mechanical shock	< 1% after fall from 1m
Operating temperature range	0 – 50 °C
Storage temperature	-20 to +50 °C
Recommended storage temperature	+5 to +15 °C
Temperature compensation	Integrated NTC network
Temperature compensation error	0 °C to 50 °C, 5% relative error
Nominal sensor life	≥ 500,000 % oxygen hours
Long term output drift	< 1% volume oxygen per month, typically < -15% over sensor lifetime.
Shelf life	24 months
Load required	≥ 10 K Ohms
Input - membrane protection grille	No
Input - hydrophobic membrane	Yes
Conformal coating on PCB	Yes
Pressure equalization - PCB	Yes
Pressure equalization - output cap	None
Weight (approximate)	28 g
Flow diverter	No
Packaging	Gas barrier bag - clear
Warranty period	12 months from date of sales invoice

All specifications are applicable at standard conditions: 1013 mbar, 25 °C dry ambient air.

Drawings/images

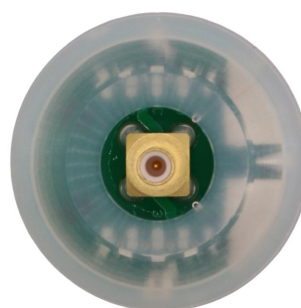
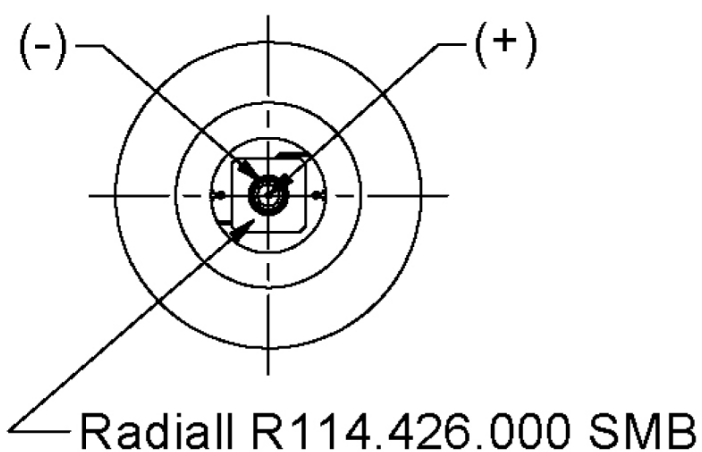
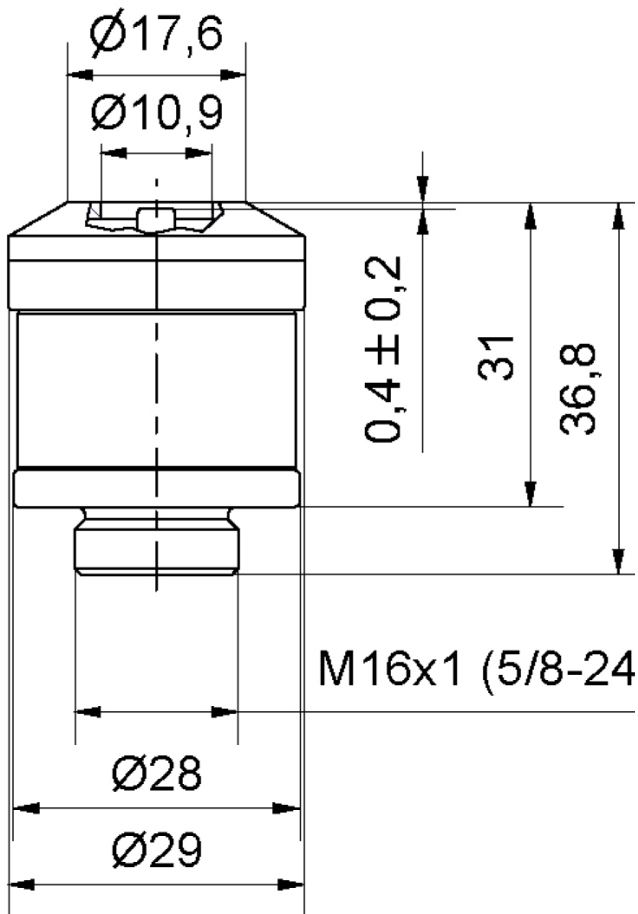

Labelling

Oxygen sensor label 90.0mm x 15.0mm

White vinyl label, text & graphics - black

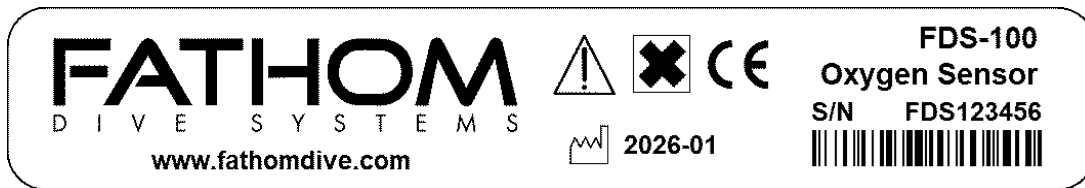

Gas barrier bag label 63.5mm x 46.6mm

White label, text & graphics – black

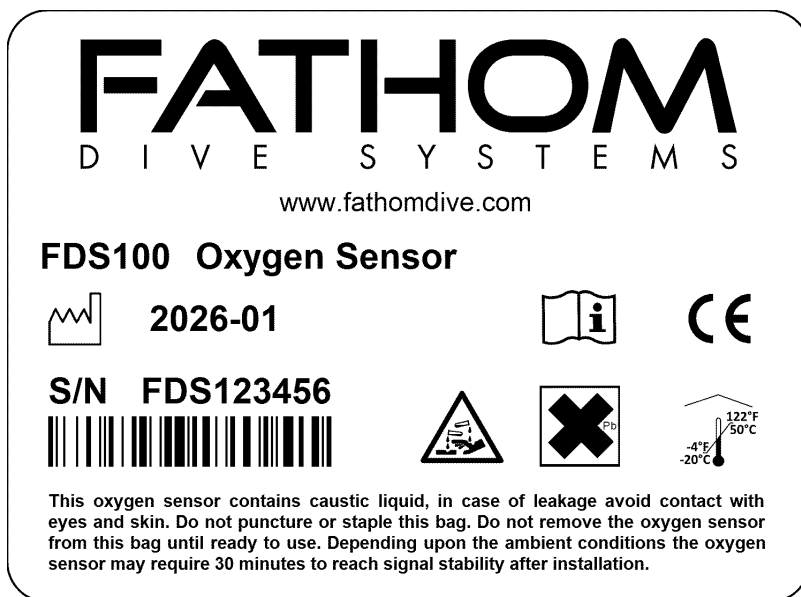

NOTE: Serial number prefix to be **FDS** e.g. **FDS123456**